

- 01 - BARRA CHATA
- 02 - CANTONEIRA ABAS IGUAIS E DESIGUAIS
- 03 - TUBO RETANGULAR
- 04 - TUBO QUADRADO
- 05 - TUBO REDONDO
- 06 - PERFIL U ABAS IGUAIS
- 06 - PERFIL U ABAS DESIGUAIS
- 07 - VERGALHÃO QUADRADO
- 07 - VERGALHÃO REDONDO
- 08 - BOX ACRÍLICO E TEMPERADO
- 09 - GRADIL E PORTÕES
- 10 - MÓVEIS
- 11 - DECORAÇÃO
- 12 - REGUAS
- 13 - BARCO
- 14 - CONTRA MARCO
- 15 - DIVERSOS
- 16 - CARROCERIAS
- 17 - PORTAS E JANELAS

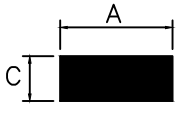

BARRA CHATA

	PESO (Kg/m)	POLEGADA		MILIMETRO	
		A	C	A	C
BC-056	0,090	3/8"	1/8"	09,52	3,17
BC-017	0,103	1/2"	—	12,70	3,00
BC-001	0,108	1/2"	1/8"	12,70	3,17
BC-002	0,135	5/8"	1/8"	15,87	3,17
BC-003	0,205	5/8"	3/16"	15,87	4,76
BC-016	0,272	5/8"	1/4"	15,87	6,35
BC-048	0,162	3/4"	1/8"	19,05	3,18
BC-013	0,245	3/4"	3/16"	19,05	4,76
BC-015	0,326	3/4"	1/4"	19,05	6,35
BC-014	0,491	3/4"	3/8"	19,05	9,52
BC-010	0,189	7/8"	1/8"	22,22	3,17
BC-004	0,219	1"	1/8"	25,40	3,17
BC-018	0,324	1"	3/16"	25,40	4,76
BC-045	0,435	1"	1/4"	25,40	6,35
BC-011	0,874	1"	1/2"	25,40	12,70
BC-005	0,273	1.1/4"	1/8"	31,75	3,17
BC-025	0,410	1.1/4"	3/16"	31,75	4,76
BC-052	0,830	1.1/4"	3/8"	31,75	9,52
BC-050	1,092	1.1/4"	1/2"	31,75	12,70
BC-058	0,930	—	—	34,70	9,70
BC-006	0,327	1.1/2"	1/8"	38,10	3,17
BC-009	0,489	1.1/2"	3/16"	38,10	4,76
BC-057	0,660	1.1/2"	1/4"	38,10	6,35
BC-012	0,984	1.1/2"	3/8"	38,10	9,52
BC-049	0,438	2"	1/8"	50,80	3,18
BC-007	0,653	2"	3/16"	50,80	4,76
BC-055	1,312	2"	3/8"	50,80	9,52
BC-051	0,400	—	—	70,00	2,00

BARRA CHATA

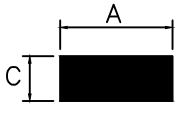
	PESO (Kg/m)	POLEGADA		MILIMETRO	
		A	C	A	C
BC-047	0,653	3"	1/8"	76,20	3,18
BC-053	1.320	3"	1/4"	76,20	6.35
BC-054	1.980	3"	3/8"	76,20	9,52

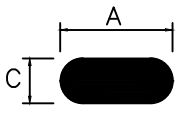
	PESO (Kg/m)	POLEGADA		MILIMETRO	
		A	C	A	C
BCR-001	0,104	1/2"	1/8"	12,70	3,17
BCR-002	0.140	5/8	1/8"	15,87	3,17
BCR-003	0,200	5/8	3/16"	15,87	4,76
BCR-004	0,240	3/4	3/16"	19,05	4,76

CANTONEIRAS ABAS IGUAIS

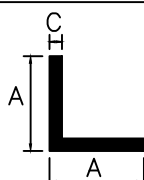
	PESO (Kg/m)	POLEGADA		MILIMETRO	
		A	C	A	C
CT-030	0,065	1/2"	–	12,70	0,80
CT-021	0,066	1/2"	–	12,70	1,00
CT-008	0,101	1/2"	1/16"	12,70	1,58
CT-031	0,075	5/8"	–	15,87	0,80
CT-020	0,083	5/8"	–	15,87	1,00
CT-002	0,129	5/8"	1/16"	15,87	1,58
CT-032	0,085	3/4"	–	19,05	0,80
CT-012	0,100	3/4"	–	19,05	1,00
CT-001	0,156	3/4"	1/16"	19,05	1,58
CT-029	0,184	7/8"	1/16"	22,22	1,58
CT-033	0,110	1"	–	25,40	0,80
CT-003	0,210	1"	1/16"	25,40	1,58
CT-005	0,312	1"	3/32"	25,40	2,38
CT-004	0,409	1"	1/8"	25,40	3,17
CT-011	0,140	1"	–	25,40	1,20
CT-023	0,265	1.1/4"	1/16"	31,75	1,58
CT-007	0,518	1.1/4"	1/8"	31,75	3,17
CT-024	0,319	1.1/2"	1/16"	38,10	1,58
CT-006	0,627	1.1/2"	1/8"	38,10	3,17
CT-025	0,537	2"	–	50,80	2,00
CT-010	0,845	2"	1/8"	50,80	3,17
CT-009	1.249	2"	3/16"	50,80	4,76
CT-026	1.064	2.1/2"	1/8"	63,50	3,17
CT-027	1.571	2.1/2"	3/16"	63,50	4,76

CANTONEIRAS ABAS DESIGUAIS

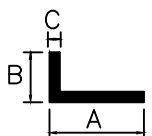
	PESO (Kg/m)	MILIMETRO			POLEGADA		
		A	B	C	A	B	C
CT-013	0,262	25,40	15,88	2,00	1"	5/8"	—
CT-014	0,196	25,40	12,70	2,00	1"	1/2"	—
CT-015	0,328	40,00	11,30	2,50	—	—	—
CT-019	0,760	38,10	25,40	4,76	1.1/2"	1"	3/16"
CT-018	0,922	50,80	25,40	4,76	2"	1"	3/16"

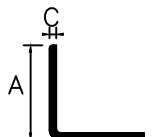
	PESO (Kg/m)	POLEGADA		MILIMETRO	
		A	C	A	C
CT-030	0,065	1/2"	—	12,70	0,80
CT-031	0,075	5/8"	—	15,87	0,80
CT-032	0,085	3/4"	—	19,05	0,80
CT-033	0,110	1"	—	25,40	0,80

TUBO RETANGULAR

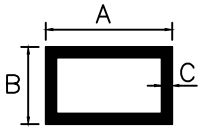
	PESO (Kg/m)	POLEGADA			MILIMETRO		
		A	B	C	A	B	C
TG-003	0,160	1"	1/2"		25,40	12,70	0,80
TG-011	0,300	1"	1/2"	1/16"	25,40	12,70	1,58
TG-008	0,440	1.1/2"	1/2"	1/16"	38,10	12,70	1,58
TG-012	0,643	1.1/2"	1"	—	38,10	25,40	2,00
TG-002	0,323	2"	1"	—	50,80	25,40	0,80
TG-006	0,402	2"	1"	—	50,80	25,40	1,00
TG-005	0,625	2"	1"	1/16"	50,80	25,40	1,58
TG-007	0,920	2"	1.1/2"	—	50,80	38,10	2,00
TG-001	0,780	2"	1"	—	50,80	25,40	2,00
TG-004	0,904	3"	1.1/2"	—	76,20	38,10	1,50
TG-009	1.236	—	—	—	95,00	50,80	1,60
TG-022	0,820	3"	1"	—	76,20	25,40	1,58
TG-021	1.260	4"	2"	—	101,60	50,80	1,48

TUBO QUADRADO

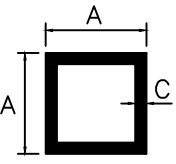
	PESO (Kg/m)	POLEGADA		MILIMETRO	
		A	C	A	C
TQ-019	0,100	3/8"	–	9,52	1,00
TQ-010	0,113	1/2"	–	12,70	0,90
TQ-018	0,236	5/8"	–	15,87	1,50
TQ-009	0,298	3/4"	–	19,05	1,50
TQ-007	0,264	1"	–	25,40	1,00
TQ-006	0,407	1"	1/16"	25,40	1,58
TQ-012	0,300	1.1/4"	–	31,75	0,90
TQ-008	0,516	1.1/4"	1/16"	31,75	1,58
TQ-003	0,323	1.1/2"	–	38,10	0,80
TQ-004	0,479	1.1/2"	–	38,10	1,20
TQ-001	0,625	1.1/2"	1/16"	38,10	1,58
TQ-020	0,650	–	–	40,00	1,50
TQ-005	0,801	2"	–	50,80	1,50
TQ-002	1,057	2"	–	50,80	2,00
TQ-014	1,523	3"	–	76,20	1,80

TUBO REDONDO

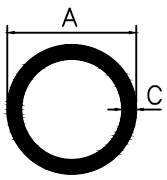
	PESO (Kg/m)	POLEGADA		MILIMETRO	
		A	C	A	C
TR-044	0,080	5/16	–	7,93	1,25
TR-024	0,106	3/8"	1/16"	9,52	1,58
TR-043	0,106	1/2"	–	12,70	1,00
TR-022	0,149	1/2"	1/16"	12,70	1,58
TR-005	0,126	5/8"	–	15,87	1,00
TR-006	0,191	5/8"	1/16"	15,87	1,58
TR-015	0,120	3/4"	–	19,05	0,80
TR-036	0,154	3/4"	–	19,05	1,00
TR-004	0,234	3/4"	1/16"	19,05	1,58
TR-032	0,682	3/4"	–	19,05	6,27
TR-026	0,180	7/8"	–	22,22	1,00
TR-021	0,277	7/8"	1/16"	22,22	1,58
TR-027	0,207	1"	–	25,40	1,00
TR-030	0,246	1"	–	25,40	1,20
TR-008	0,319	1"	1/16"	25,40	1,58
TR-017	0,343	1"	–	25,40	1,70
TR-007	0,397	1"	–	25,40	2,00
TR-009	0,598	1"	1/8"	25,40	3,17
TR-048	0,175	1"	–	25,40	0,80
TR-018	0,180	1.1/8"	1/32"	28,58	0,80
TR-039	0,220	1.1/8"	–	28,58	1,00
TR-040	0,245	1.1/4"	–	31,75	1,00
TR-020	0,405	1.1/4"	1/16"	31,75	1,58
TR-045	0,520	1.1/4"	–	31,75	2,00
TR-025	0,780	1.1/4"	1/8"	31,75	3,18
TR-010	0,489	1.1/2"	1/16"	38,10	1,58
TR-034	0,721	1.1/2"	–	38,10	2,38
TR-003	0,650	2"	–	50,80	1,50
TR-023	0,670	2"	1/16"	50,80	1,58

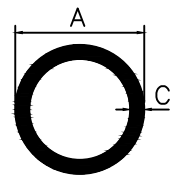
	PESO (Kg/m)	POLEGADA		MILIMETRO	
		A	C	A	C
TR-011	0,828	2"	—	50,80	2,00
TR-012	1.281	2"	1/8"	50,80	3,17
TR-013	0,830	2.1/2"	1/16"	63,50	1,58
TR-014	1.623	2.1/2"	1/8"	63,50	3,17
TR-035	1.258	3"	—	76,20	2,00
TR-028	1.279	—	—	32,00	5,75
TR-029	1.652	—	—	38,50	6,00
TR-041	0,320	—	—	16,00	3,00
TR-042	0,550	—	—	50,20	1,30
TR-046	0,980	—	—	44,45	2,70
TR-047	0,225	—	—	29,20	1,00

PERFIL "U" ABAS IGUAIS

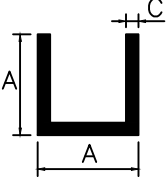
	PESO (Kg/m)	POLEGADA		MILIMETRO	
		A	C	A	C
PU-007	0,072	3/8"	–	9,52	1,00
PU-009	0,100	1/2"	–	12,70	1,00
PU-001	0,150	1/2"	–	12,70	1,58
PU-002	0,190	5/8"	–	15,88	1,58
PU-008	0,292	3/4"	–	19,05	2,00

PERFIL "U" ABAS DESIGUAIS

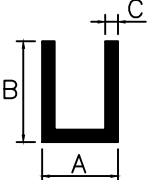
	PESO (Kg/m)	MILIMETRO		
		A	B	C
PU-303	0,130	9,52	12,70	1,50
PU-005	0,177	12,70	22,00	1,20
PU-006	0,124	14,00	15,00	1,10
PU-003	0,252	15,00	25,00	1,50
PU-004	0,195	15,00	25,00	1,15
PU-047	0,365	29,00	35,00	1,50
PU-048	0,365	14,00	48,00	1,20
PU-010	0,125	17,00	14,50	0,90

VERGALHAO QUADRADO

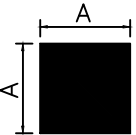
	PESO (Kg/m)	POLEGADA	MILIMETRO
		A	A
VQ-004	0,100	—	6,00
VQ-003	0,115	1/4"	6,35
VQ-001	0,246	3/8"	9,52
VQ-002	0,440	1/2"	12,70

VERGALHAO REDONDO

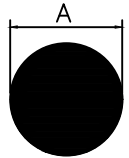
	PESO (Kg/m)	POLEGADA	MILIMETRO
		A	A
VR-004	0,085	1/4"	6,35
VR-003	0,108	—	7,14
VR-002	0,140	—	8,00
VR-005	0,192	3/8"	9,52
VR-006	0,341	1/2"	12,70
VR-010	0,550	5/8"	15,88
VR-009	0,770	3/4"	19,05
VR-007	1.180	—	23,70
VR-008	3.078	1.1/2"	38,10

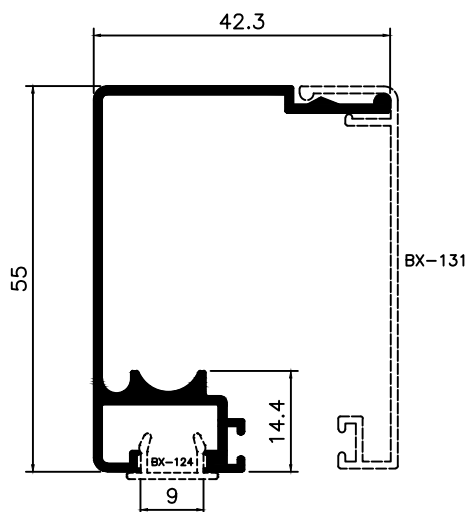

BX-130
0,540 Kg/m



BX-131
0,225 Kg/m

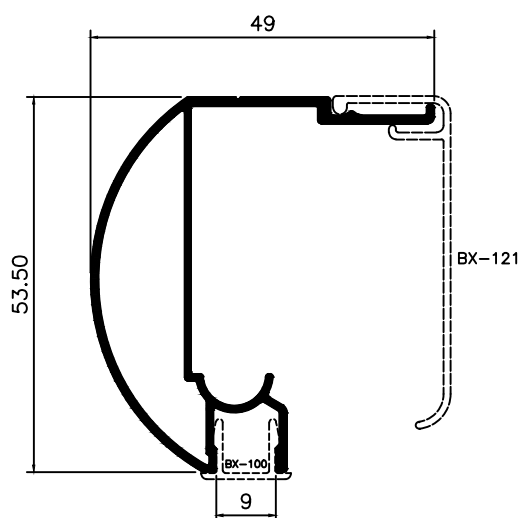

BX-119
0,521 Kg/m

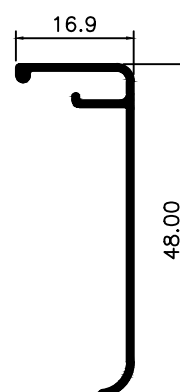

BX-121
0,198 Kg/m

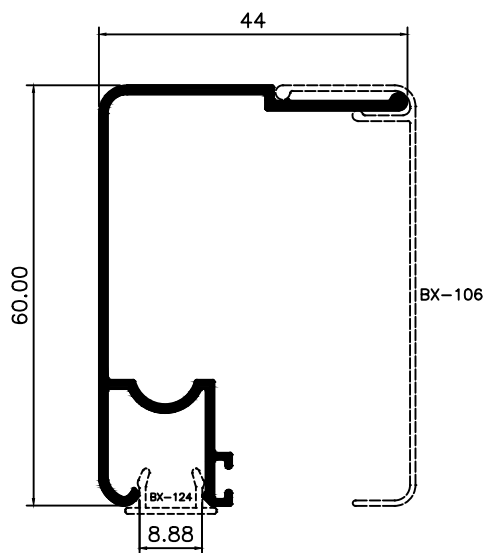

BX-105
0,535 Kg/m

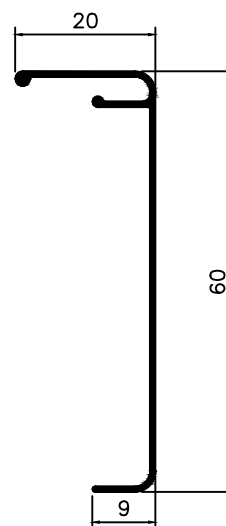

BX-106
0,240 Kg/m

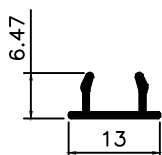

BX-124
0,060 Kg/m

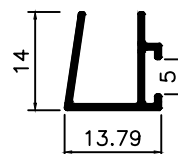

BX-143
0,115 Kg/m

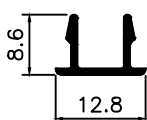

BX-100
0,078 Kg/m

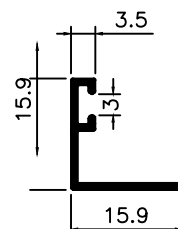

BX-184
0,102 Kg/m

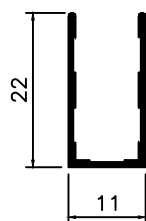

BX-102
0,122 Kg/m

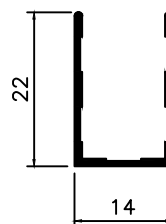

BX-103
0,140 Kg/m

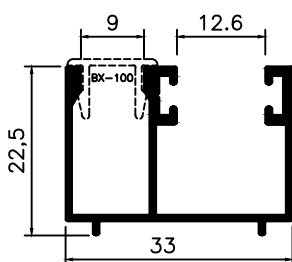

BX-104
0,335 Kg/m

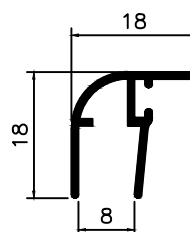

BX-138
0,150 Kg/m

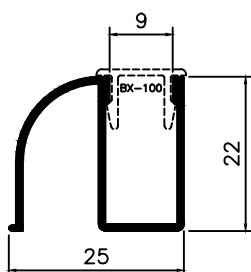

BX-110
0,230 Kg/m

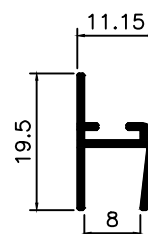

BX-122
0,130 Kg/m

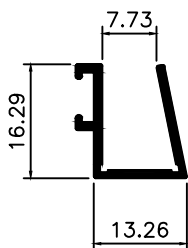

BX-111
0,165 Kg/m

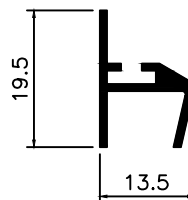

BX-123
0,145 Kg/m

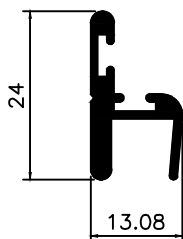

BX-099
0,275 Kg/m

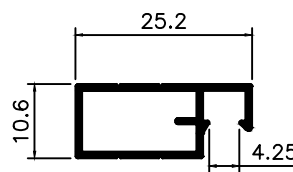

25-273
0,195 Kg/m

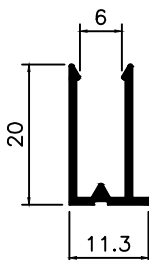

DS-474
0,150 Kg/m

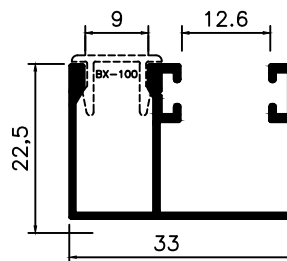

BX-107
0,330 Kg/m

BOX VIDRO TEMPERADO

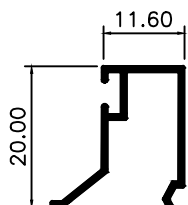

BX-125
0,160 Kg/m

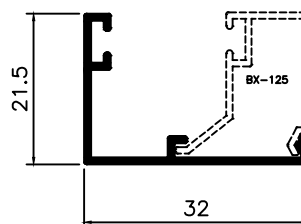

BX-126
0,198 Kg/m

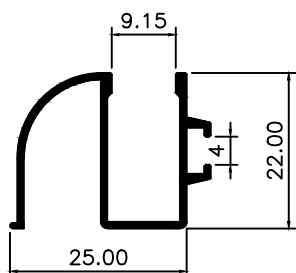

BX-185
0,260 Kg/m



BXE-003
0,070 Kg/m

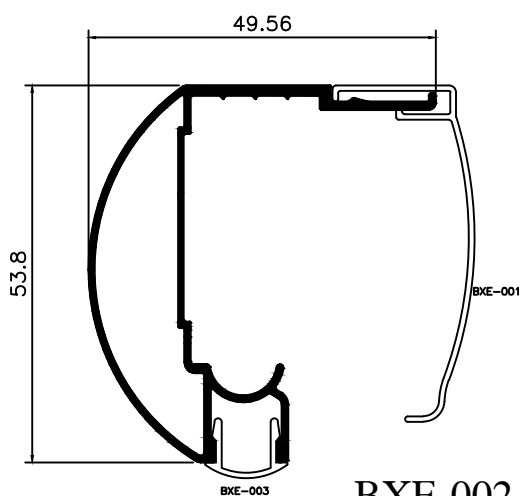

BXE-002
0,550 Kg/m

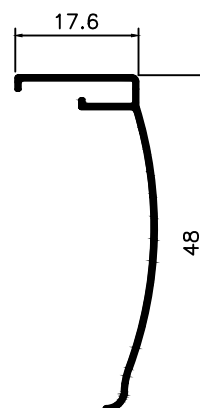

BXE-001
0,180 Kg/m

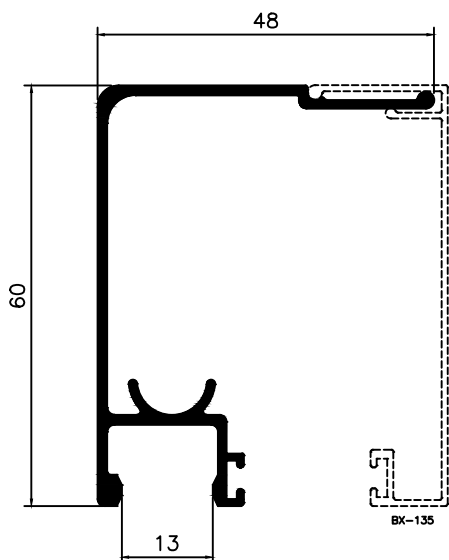

BX-134
0,630 Kg/m

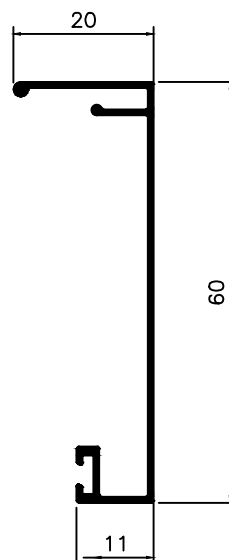

BX-135
0,275 Kg/m

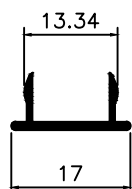

BX-190
0,100 Kg/m

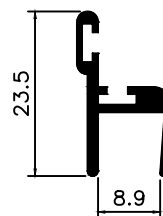

BX-186
0,200 Kg/m

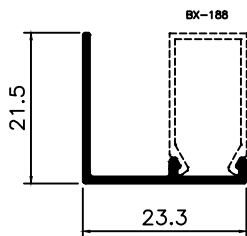

BX-187
0,145 Kg/m

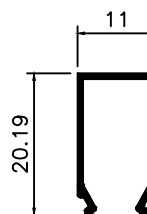

BX-188
0,130 Kg/m

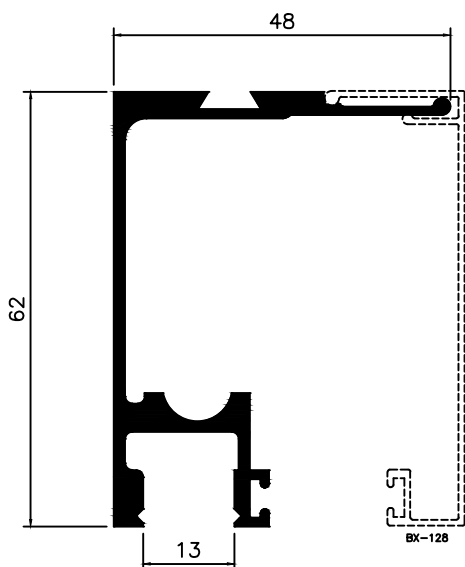

BX-127
0,920 Kg/m

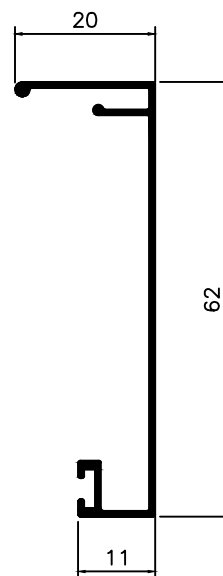

BX-128
0,280 Kg/m

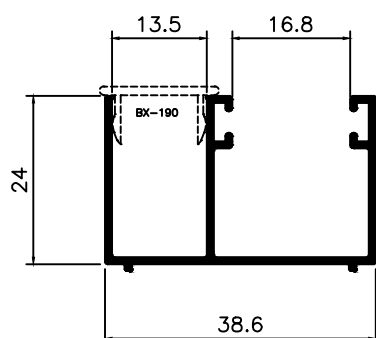

BX-191
0,350 Kg/m

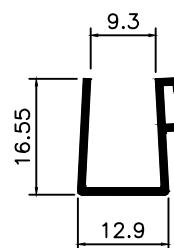

BX-189
0,145 Kg/m

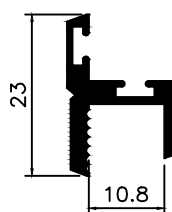

BX-192
0,240 Kg/m

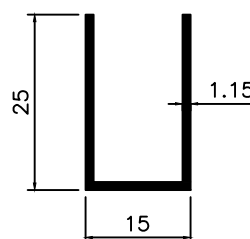

PU-004
0,210 Kg/m

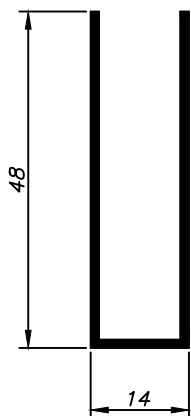

PU-048
0,365 Kg/m

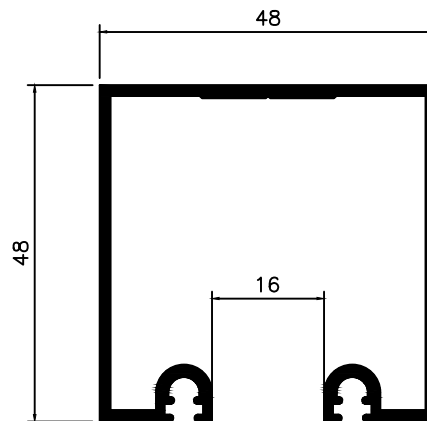

DS-086
0,850 Kg/m

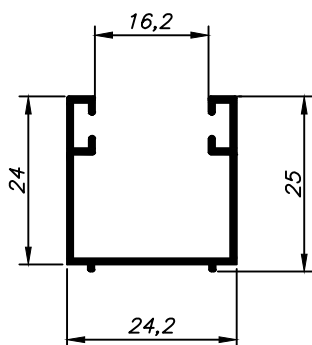

BX-139
0,238 Kg/m

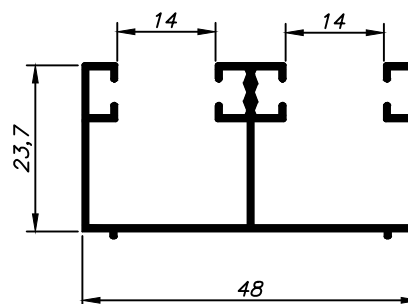

BX-140
0,430 Kg/m

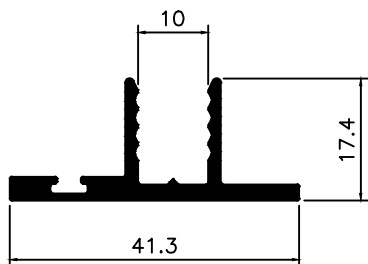

VT-001
0,420 Kg/m

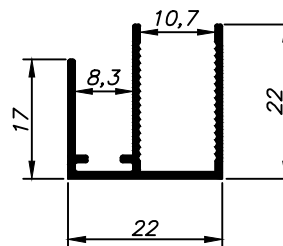

BX-141
0,220 Kg/m

BOX ACRÍLICO

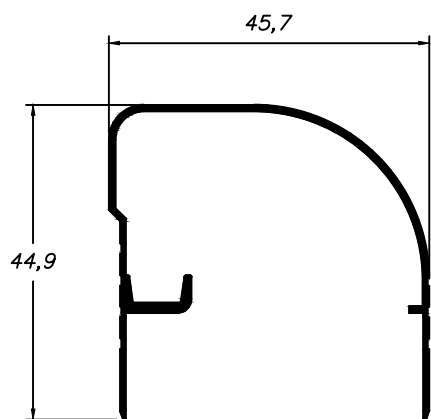

BX-055
0,375 Kg/m

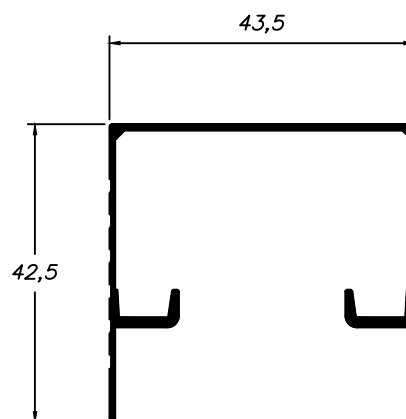

BX-183
0,396 Kg/m

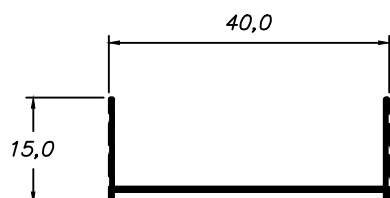

BX-050
0,150 Kg/m

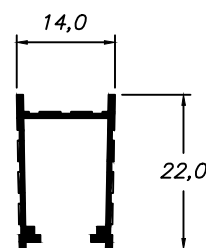

BX-051
0,155 Kg/m

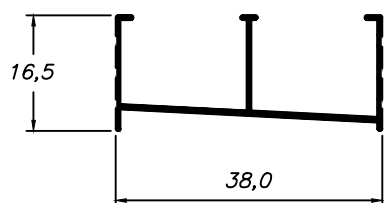

BX-052
0,185 Kg/m

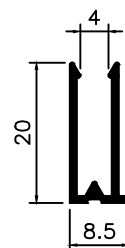

DS-477
0,140 Kg/m

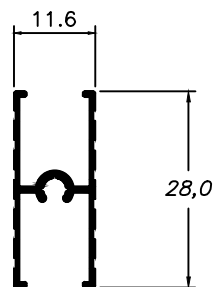

BX-053
0,172 Kg/m

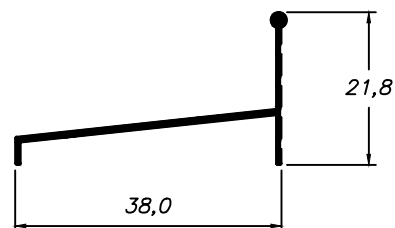

BX-054
0,160 Kg/m

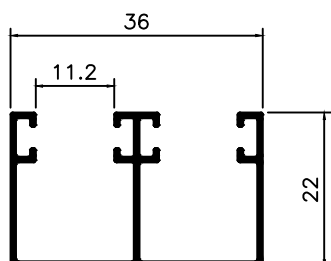

BX-193
0,300 Kg/m

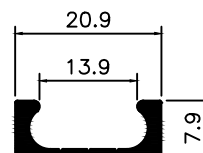

BX-194
0,165 Kg/m

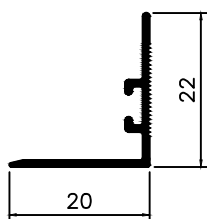

BX-195
0,135 Kg/m

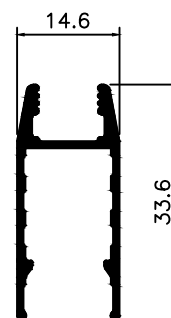

BX-196
0,295 Kg/m

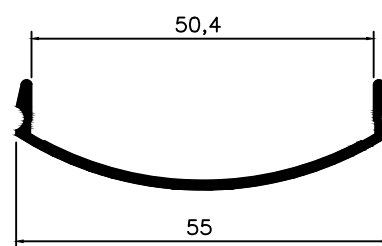
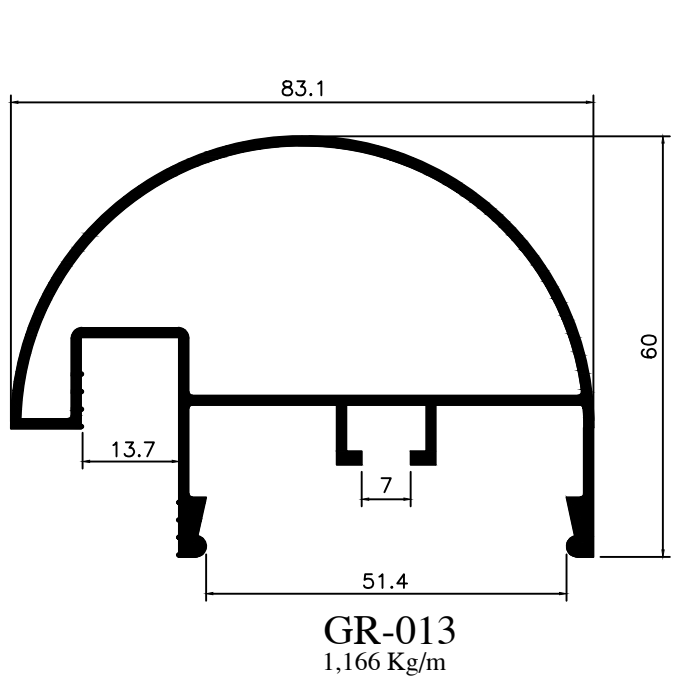

GR-074
0,250 Kg/m

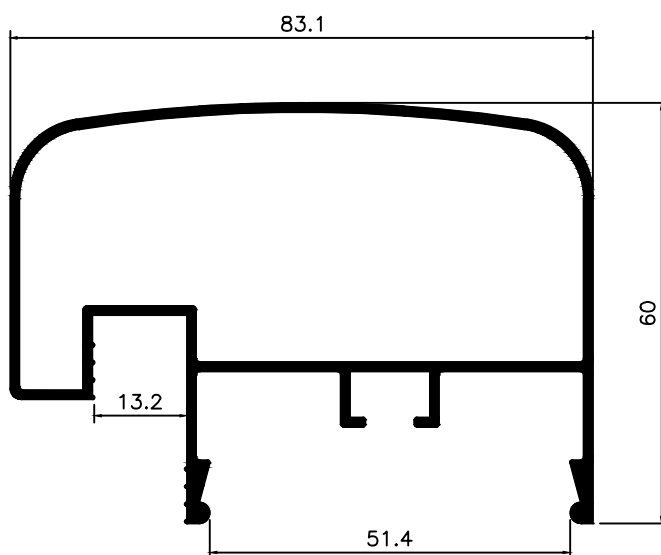

GR-083
1,187 Kg/m

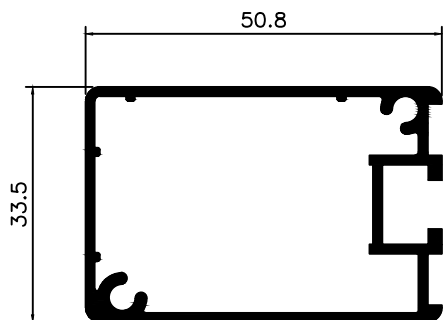

GR-077
0,745 Kg/m

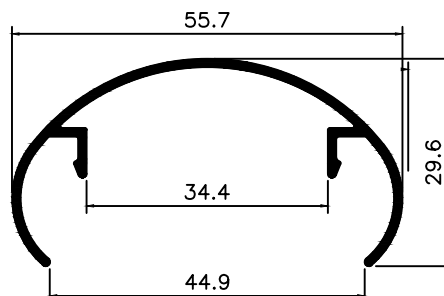

GR-078
0,385 Kg/m

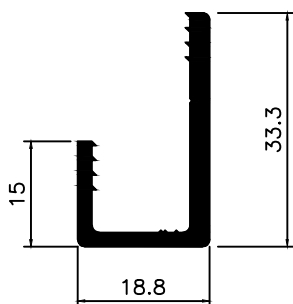

GR-075
0,420 Kg/m

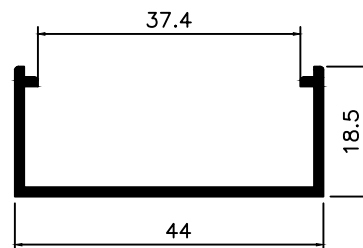

GR-079
0,280 Kg/m

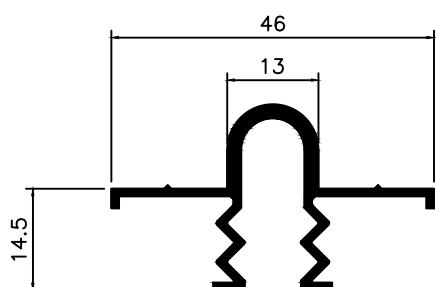

DS-060
0,396 Kg/m

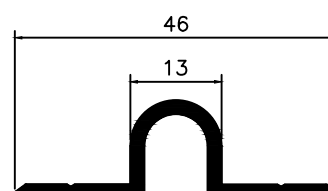

DS-058
0,310 Kg/m

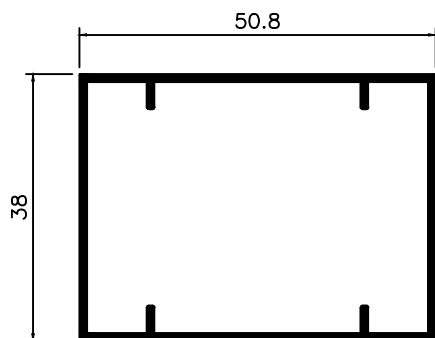

DS-050
0,561 Kg/m

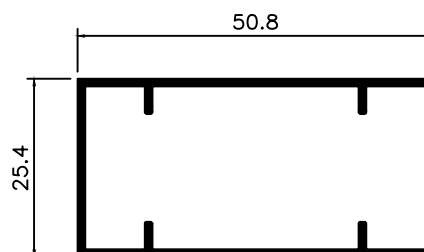

DS-051
0,520 Kg/m

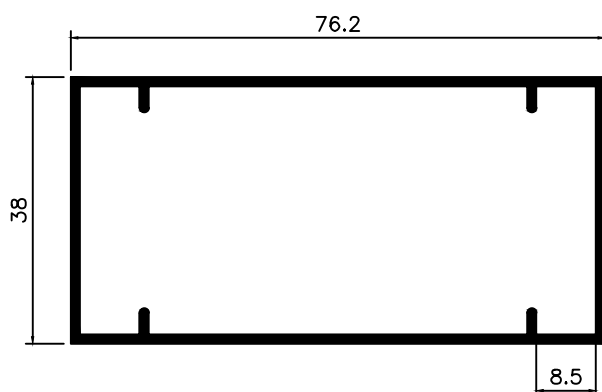

DS-052
0,837 Kg/m

DS-052N
0,720 Kg/m

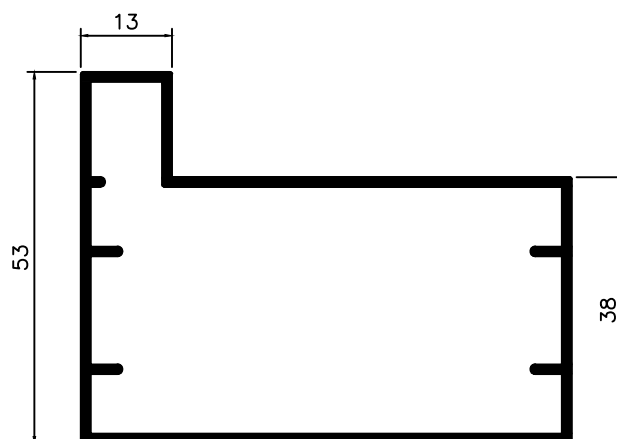

DS-062
0,990 Kg/m

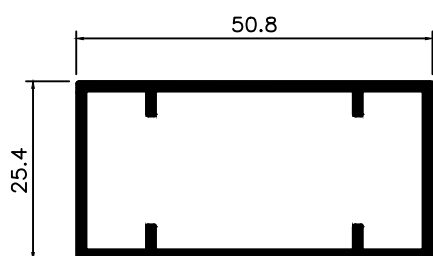

DS-063
0,630 Kg/m

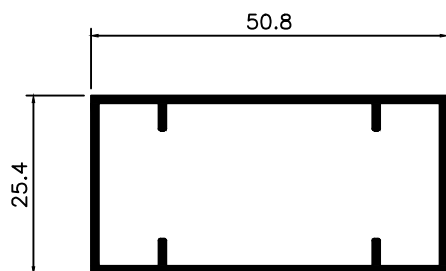

RF-043
0,450 Kg/m

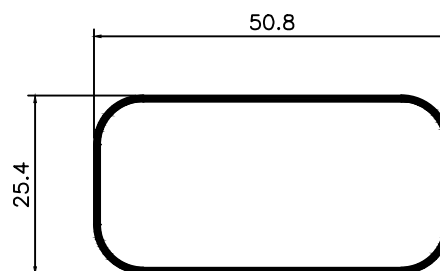

TGR-001
0,320 Kg/m

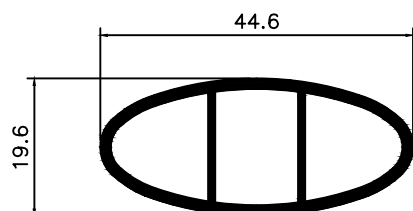

MV-025
0,495 Kg/m

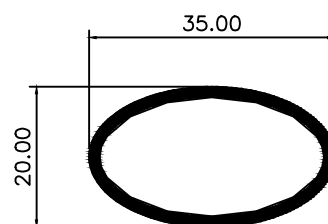

MV-006
0,340 Kg/m

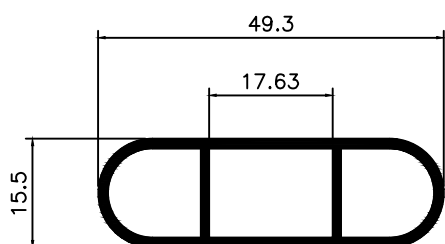

MV-003
0,550 Kg/m



MV-004
0,491 Kg/m

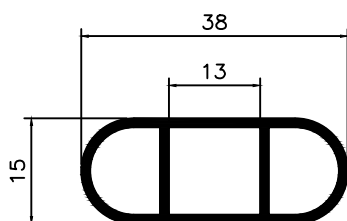

MV-005
0,365 Kg/m

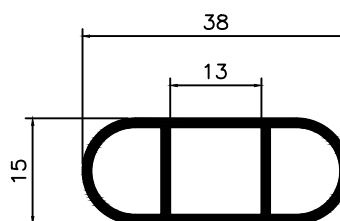

MV-008
0,386 Kg/m

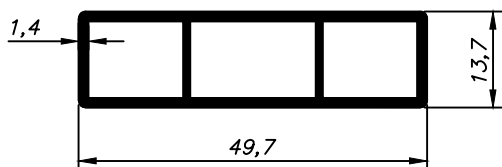

MV-007
0,528 Kg/m

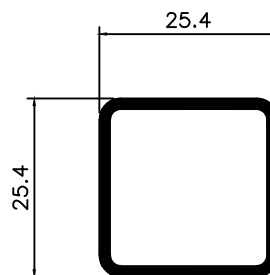

TQ-006CR
0,400 Kg/m

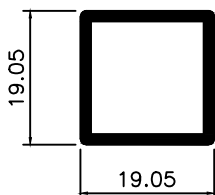

TQ-009
0,298 Kg/m

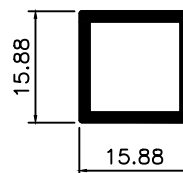

TQ-018
0,236 Kg/m

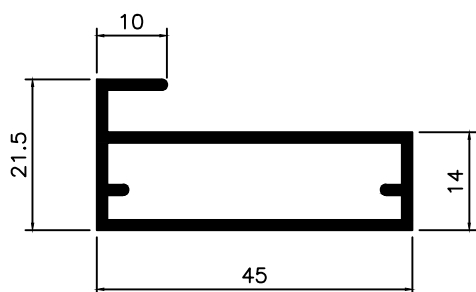

MV-009
0,540 Kg/m

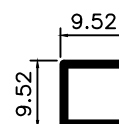

TQ-019
0,100 Kg/m

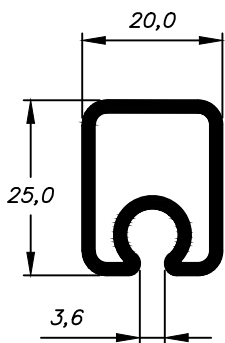

MV-072
0,490 Kg/m

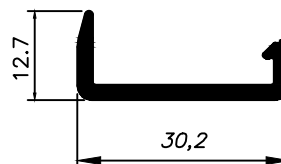

MV-073
0,290 Kg/m

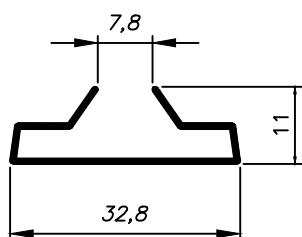

MV-070
0,160 Kg/m

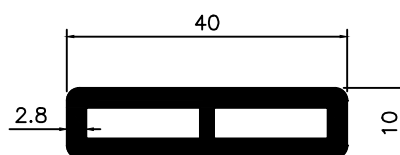

DS-479
0,690 Kg/m

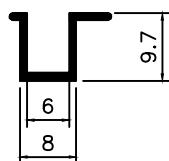

MV-015
0,090 Kg/m

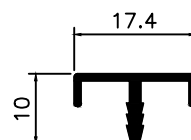

MV-019
0,108 Kg/m

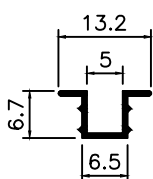

MV-020
0,060 Kg/m

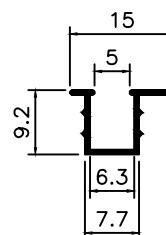

MV-021
0,065 Kg/m

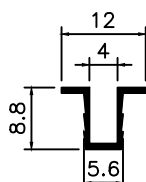

MV-042
0,060 Kg/m

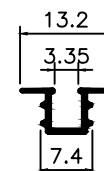

MV-044
0,060 Kg/m

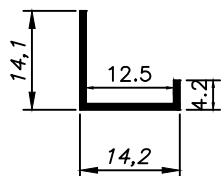

MV-046
0,080 Kg/m

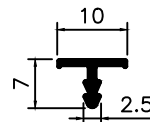

MV-039
0,070 Kg/m

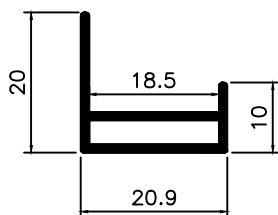

MV-053
0,230 Kg/m



MV-054
0,100 Kg/m

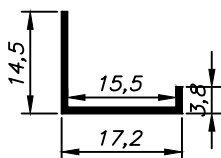

MV-067
0,080 Kg/m

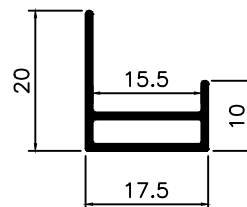

MV-068
0,175 Kg/m

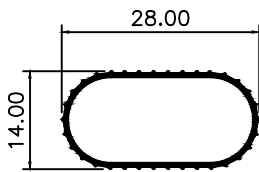

MV-023
0,125 Kg/m

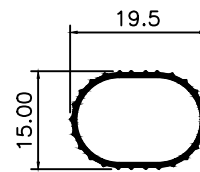

MV-024
0,100 Kg/m

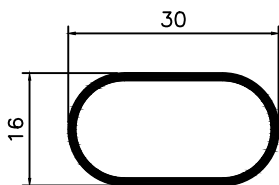

DS-054
0,213 Kg/m

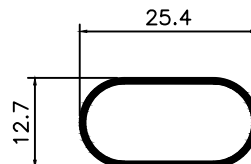

DS-056
0,136 Kg/m

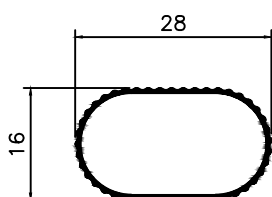

MV-055
0,120 Kg/m

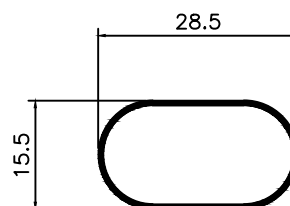

MV-059
0,145 Kg/m

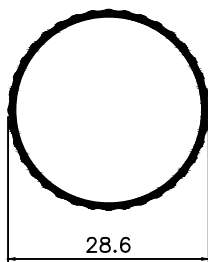

TR-200
0,207 Kg/m

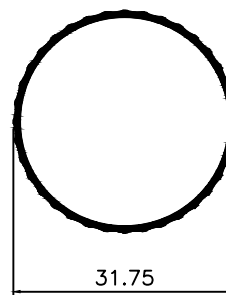

TR-201
0,231 Kg/m

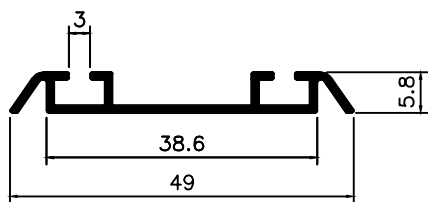

MV-012
0,238 Kg/m

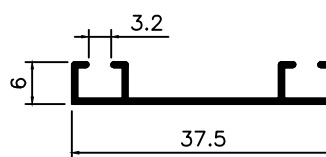

MV-017
0,138 Kg/m

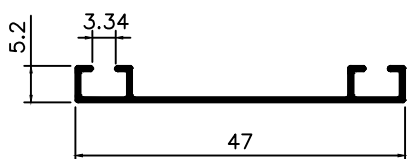

MV-029
0,160 Kg/m

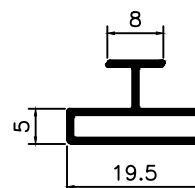

MV-030
0,160 Kg/m

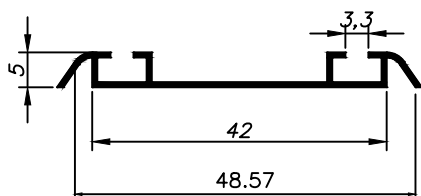

MV-035
0,175 Kg/m

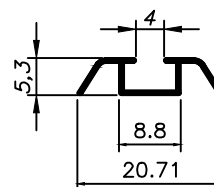

MV-051
0,085 Kg/m



MV-052
0,145 Kg/m

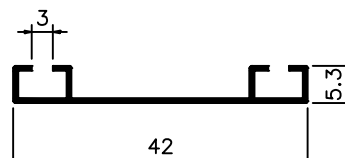

MV-061
0,140 Kg/m

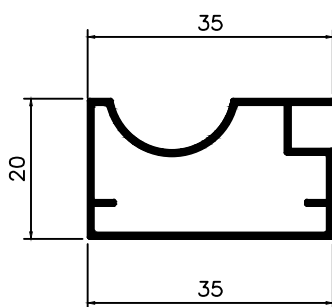

MV-074
0,320 Kg/m

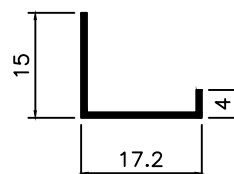

MV-075
0,080 Kg/m

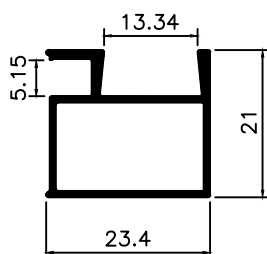

MV-076
0,260 Kg/m



MV-014
0,540 Kg/m

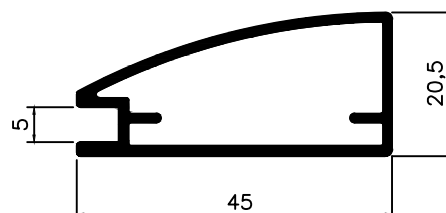

MV-026
0,500 Kg/m

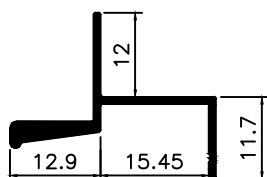

MV-027
0,210 Kg/m

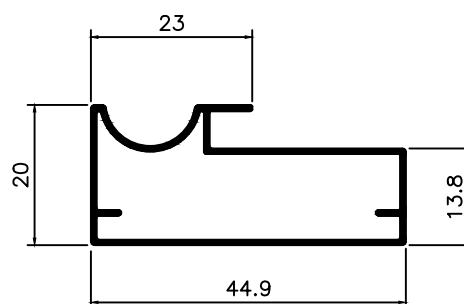

MV-028
0,330 Kg/m

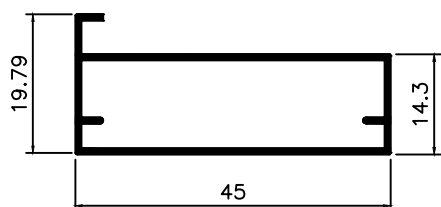

MV-031
0,330 Kg/m

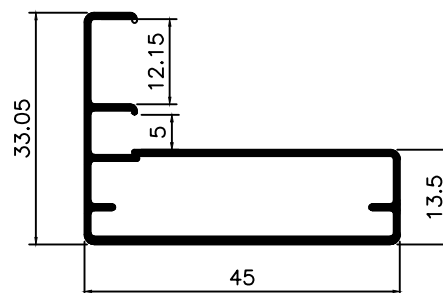

MV-037
0,420 Kg/m

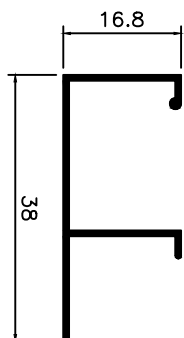

DS-106
0,170 Kg/m

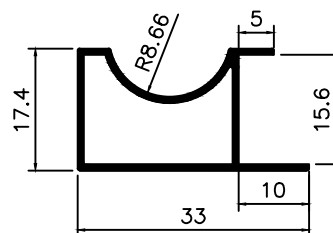

MV-041
0,260 Kg/m

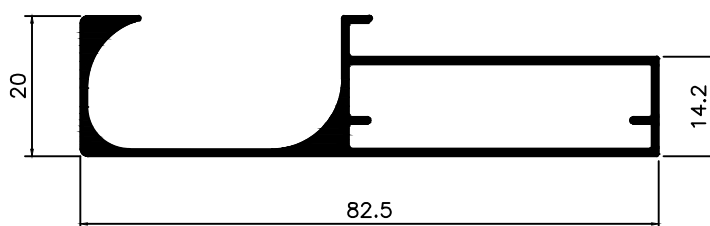

MV-043
0,690 Kg/m

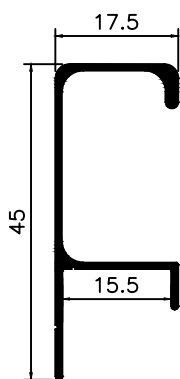

MV-022
0,260 Kg/m

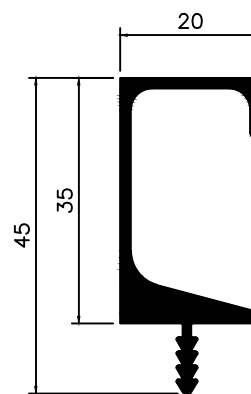

MV-010
0,518 Kg/m

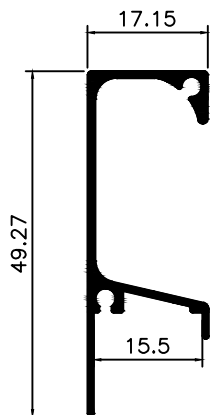

MV-045
0,320 Kg/m

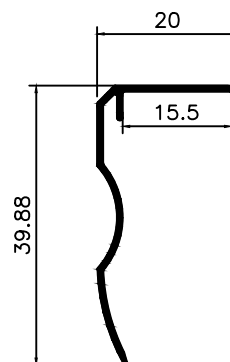

MV-049
0,190 Kg/m

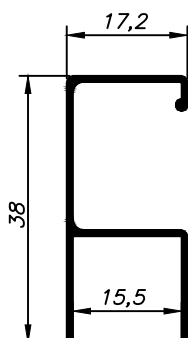

MV-047
0,220 Kg/m

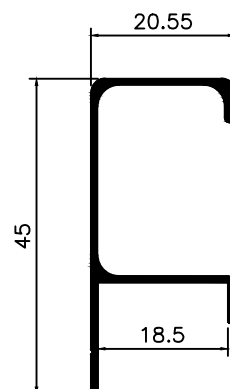

MV-048
0,270 Kg/m

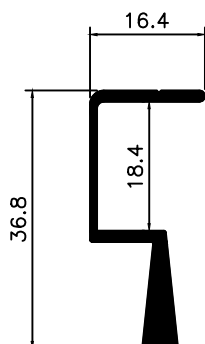

MV-038
0,320 Kg/m

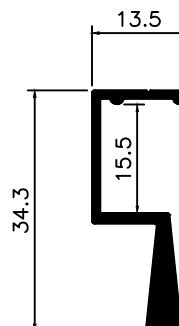

MV-060
0,305 Kg/m

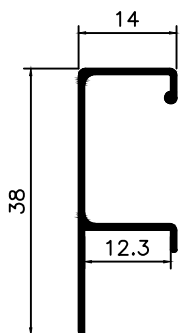

MV-050
0,180 Kg/m

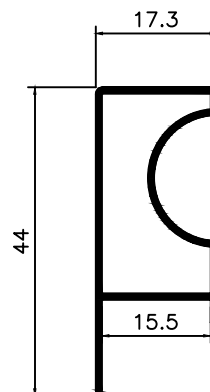

MV-063
0,300 Kg/m

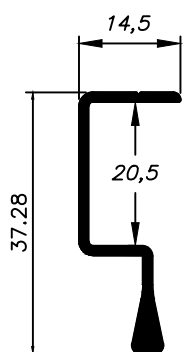

MV-064
0,270 Kg/m

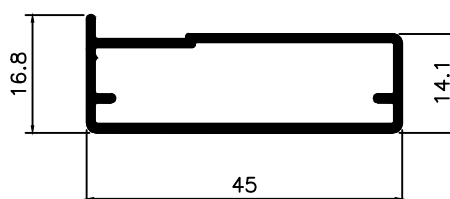

MV-065
0,420 Kg/m

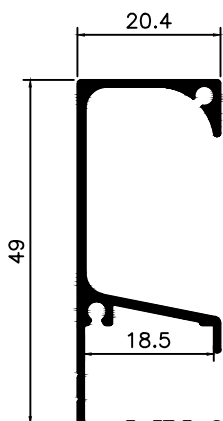

MV-066
0,340 Kg/m

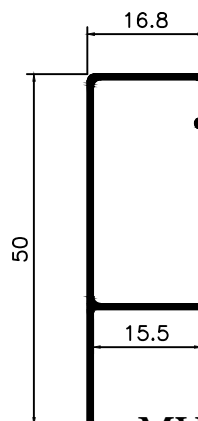

MV-069
0,220 Kg/m

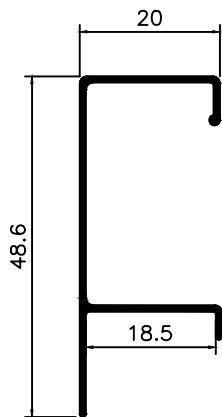

MV-080
0,240 Kg/m

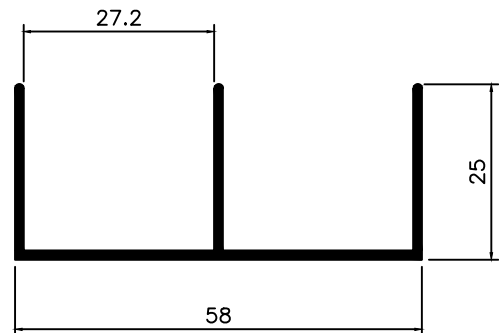

MV-011
0,432 Kg/m

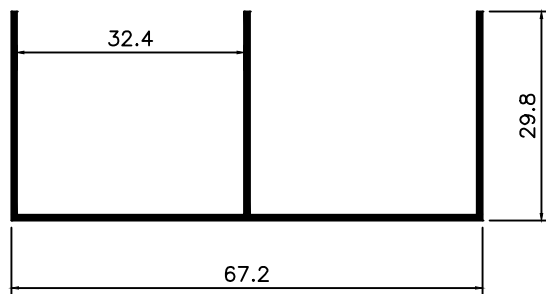

MV-033
0,345 Kg/m

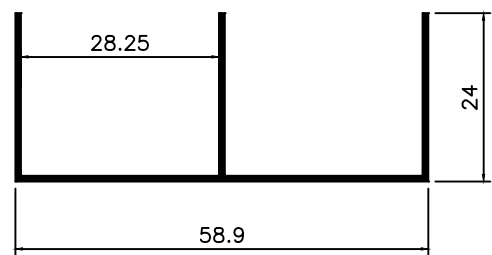

MV-034
0,290 Kg/m

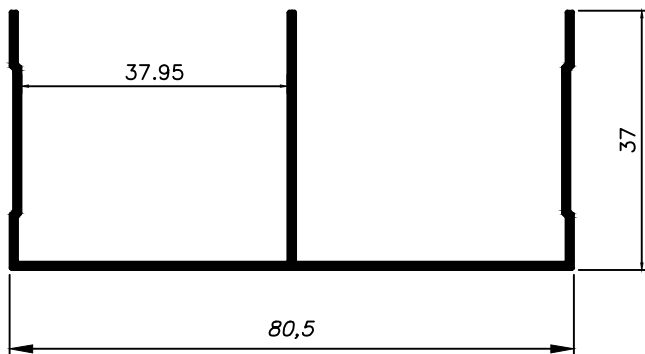

MV-071
0,630 Kg/m

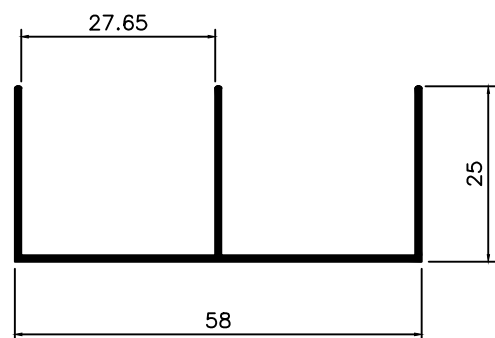

MV-018
0,316 Kg/m

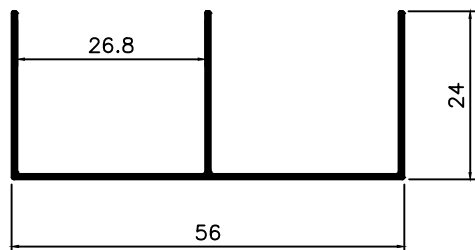

MV-056
0,285 Kg/m

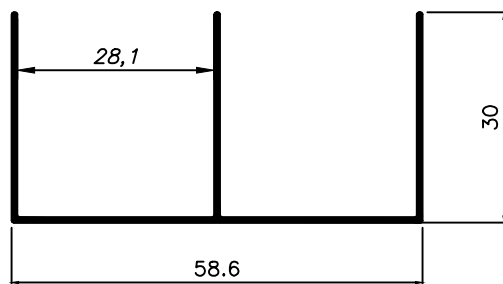

MV-057
0,325 Kg/m

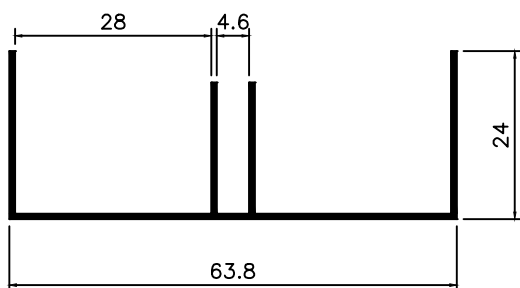

MV-058
0,335 Kg/m

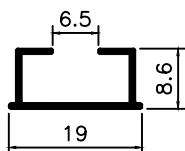

TS-001
0,100 Kg/m

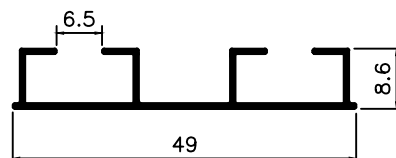

TS-002
0,220 Kg/m

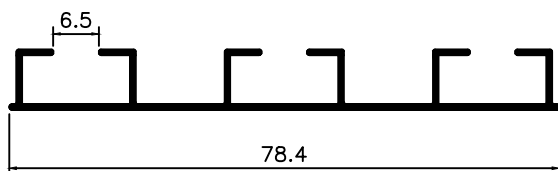

TS-003
0,330 Kg/m

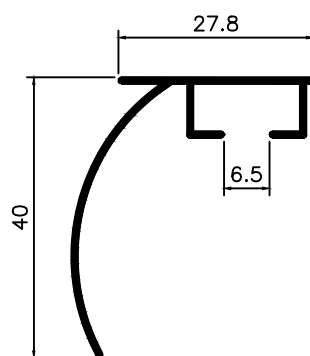

TS-004
0,245 Kg/m

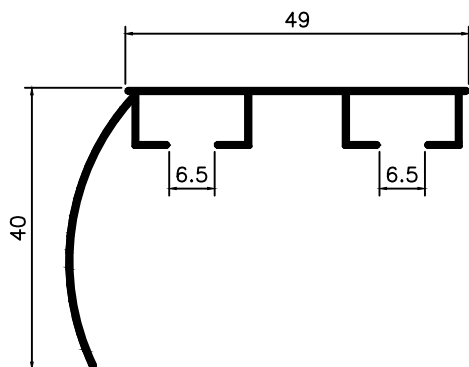

TS-005
0,345 Kg/m

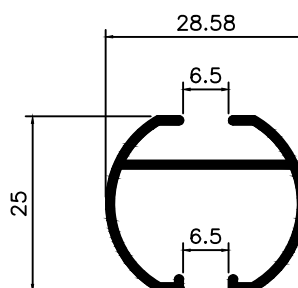

TS-009
0,325 Kg/m

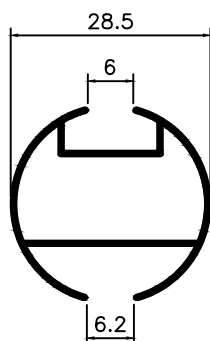

TS-010
0,270 Kg/m

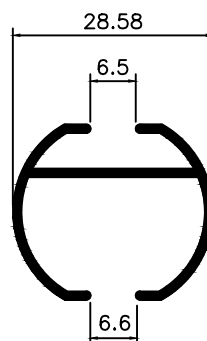

TS-011
0,320 Kg/m

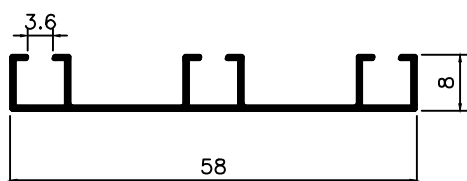

TS-012
0,330 Kg/m

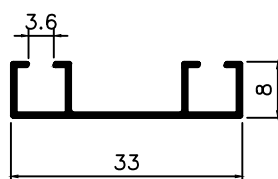

TS-013
0,245 Kg/m

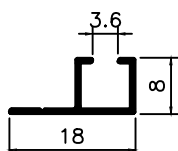

TS-014
0,087 Kg/m

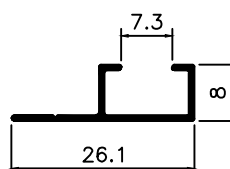

TS-015
0,110 Kg/m

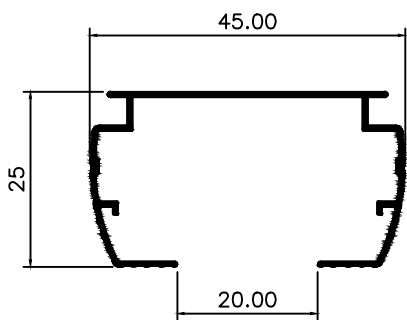

PE-001
0,256 Kg/m

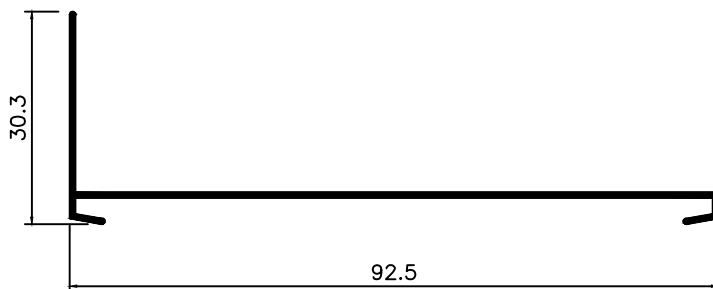

PE-002
0,290 Kg/m

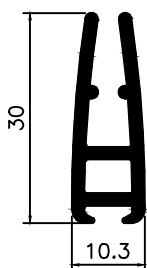

PE-004
0,370 Kg/m

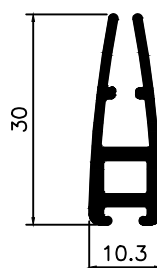

PE-008
0,320 Kg/m

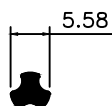

PE-003
0,047 Kg/m

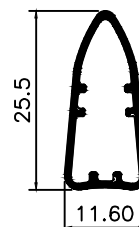

PE-011
0,185 Kg/m

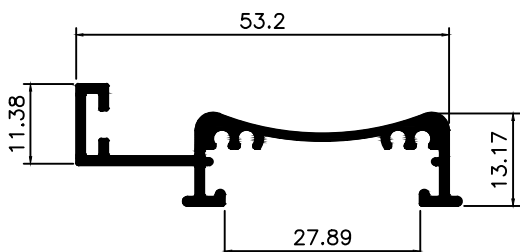

PE-005
0,450 Kg/m

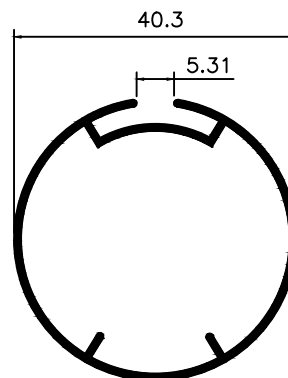

PE-006
0,440 Kg/m

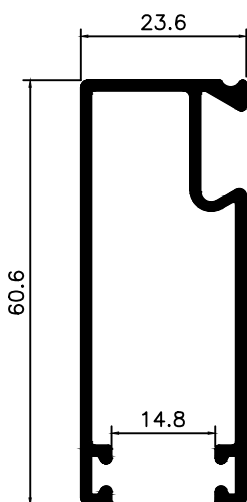

PE-007
0,690 Kg/m

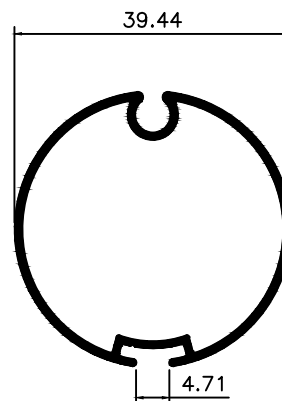

PE-009
0,425 Kg/m

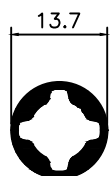

PE-010
0,205 Kg/m

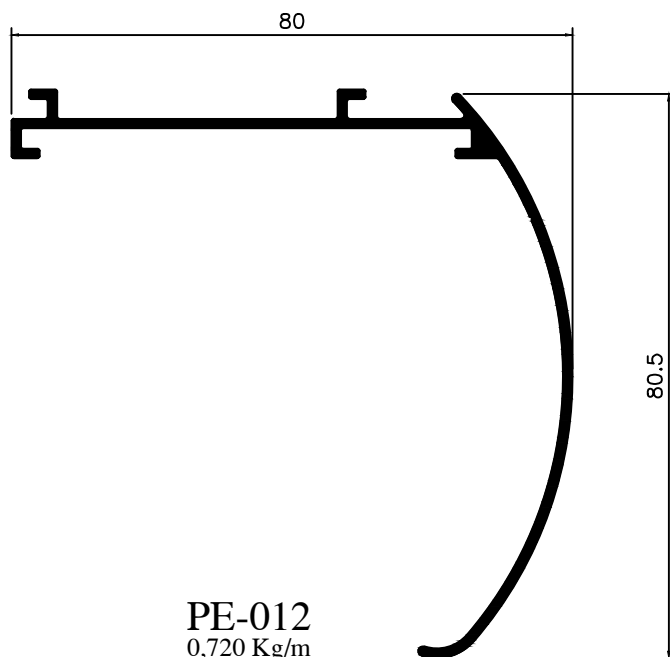

PE-012
0,720 Kg/m

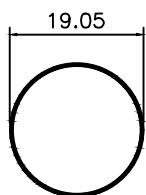

TR-015
0,120 Kg/m

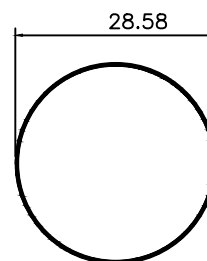

TR-018
0,180 Kg/m

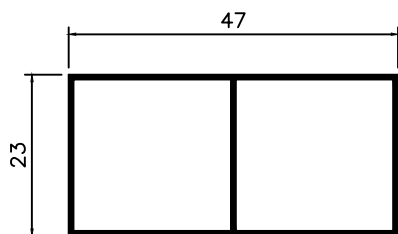

BT-001
0,300 Kg/m

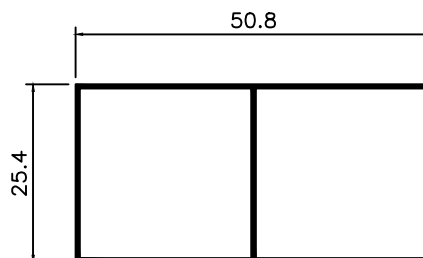

BT-002 **BT-003**
0,300 Kg/m 0,380 Kg/m

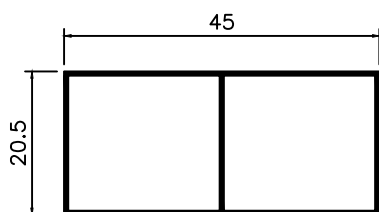

BT-009
0,250 Kg/m

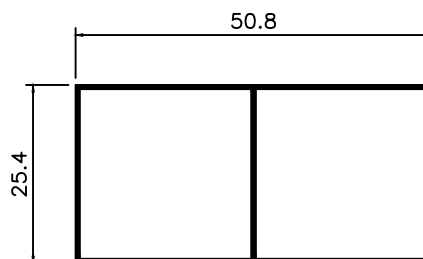

BT-004 **BT-005**
0,340 Kg/m 0,430 Kg/m

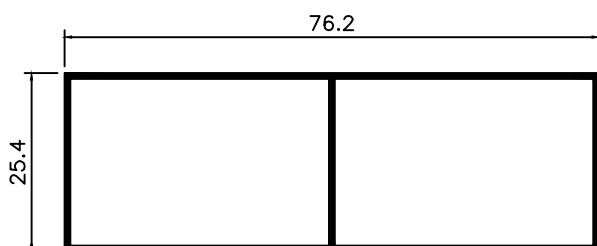

BT-010
0,485 Kg/m

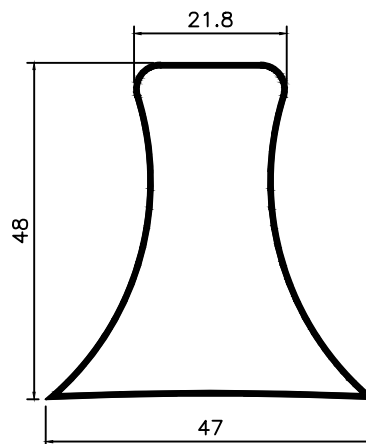

RP-001
0,340 Kg/m

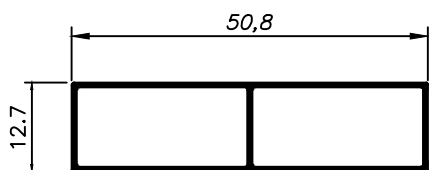

BT-006
0,260 Kg/m

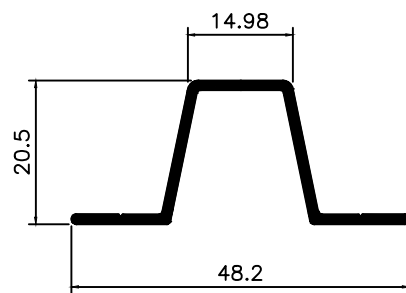

DS-120
0,368 Kg/m

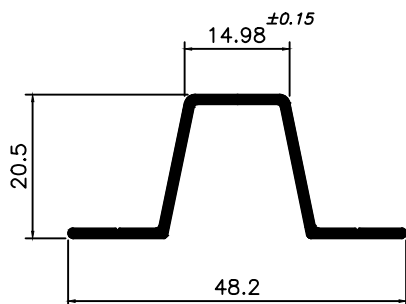

DS-121
0,510 Kg/m

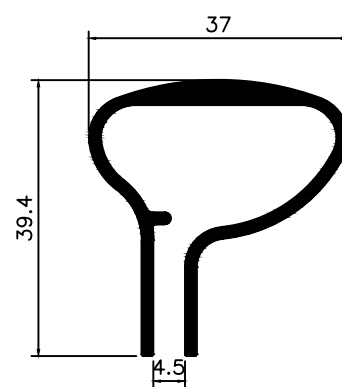

DS-123
0,650 Kg/m

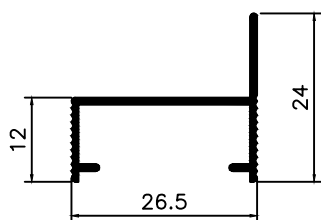

CM-064
0,180 Kg/m

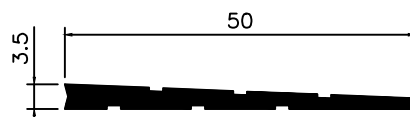

CL-011
0,320 Kg/m

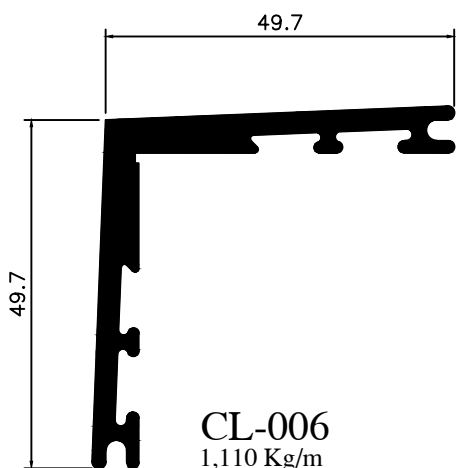

CL-006
1,110 Kg/m

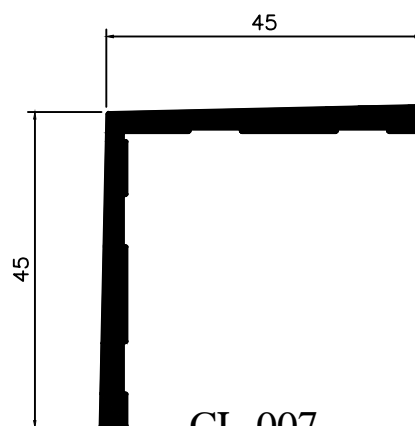

CL-007
0,810 Kg/m

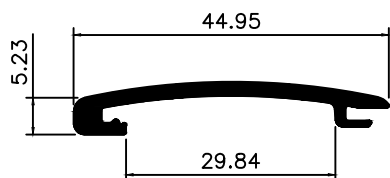

DS-025
0,310 Kg/m

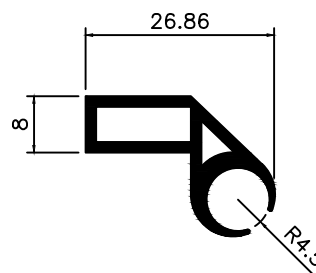

DS-105
0,350 Kg/m

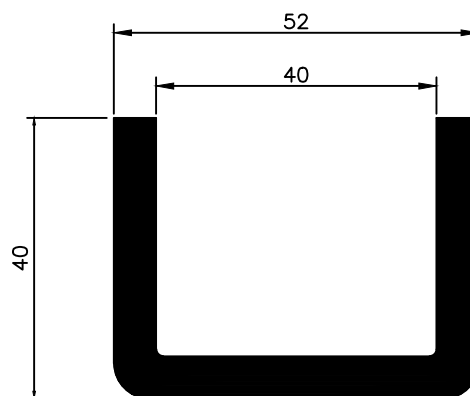

DS-456
1.930 Kg/m

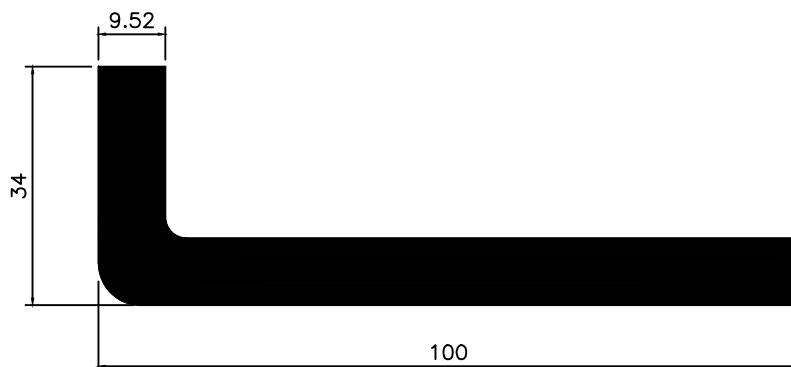

DS-457
3.210 Kg/m

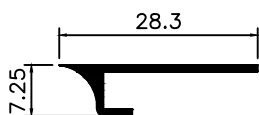

DS-226
0,120 Kg/m

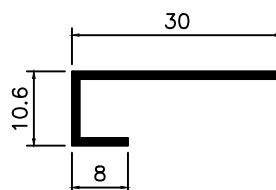

DS-225
0,150 Kg/m

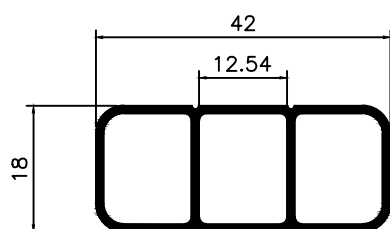

DS-038
0,430 Kg/m

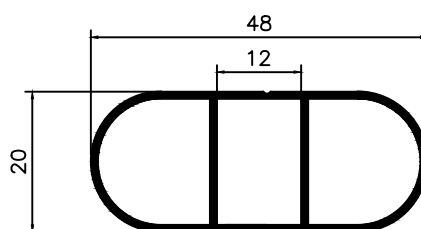

DS-037
0,420 Kg/m

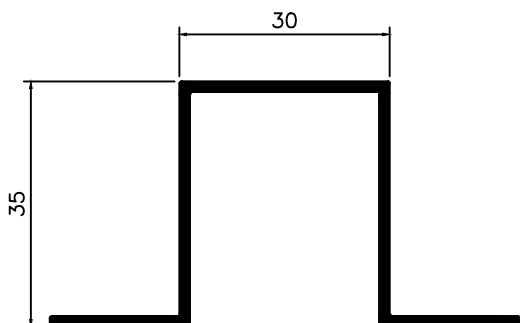

DS-243
0,550 Kg/m

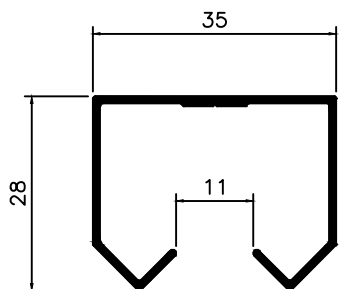

DS-228
0,320 Kg/m

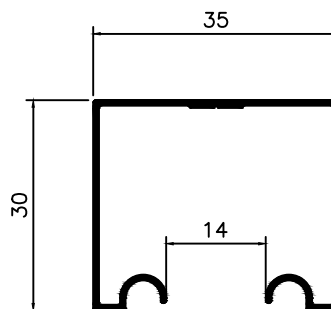

DS-229
0,290 Kg/m

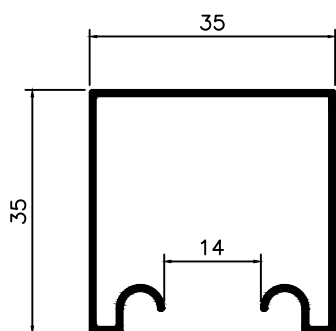

DS-230
0,340 Kg/m

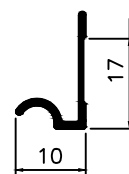

DS-231
0,080 Kg/m

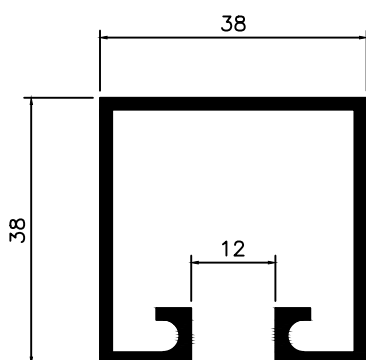

DS-055
0,730 Kg/m

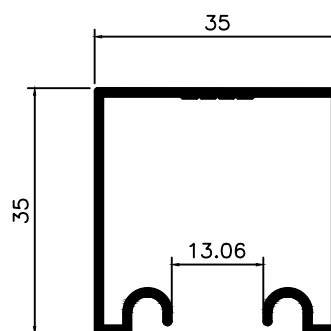

DS-236 **DS-237**
0,400 Kg/m 0,480 Kg/m

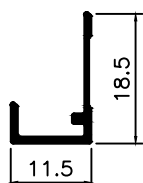

DS-232
0,105 Kg/m

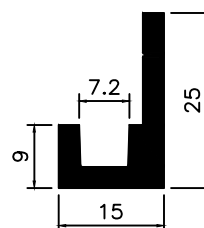

DS-235
0,395 Kg/m

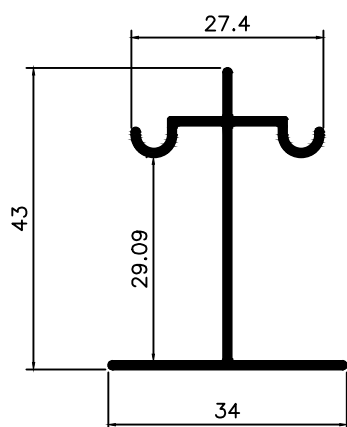

DS-239
0,380 Kg/m

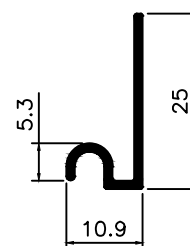

DS-240
0,145 Kg/m

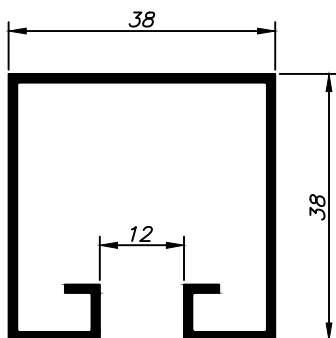

DS-241
0,515 Kg/m

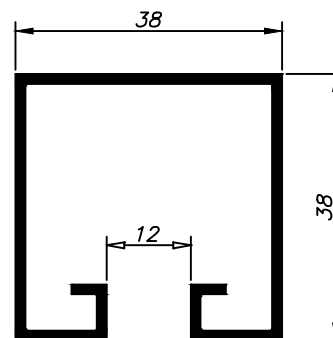

DS-471
0,595 Kg/m

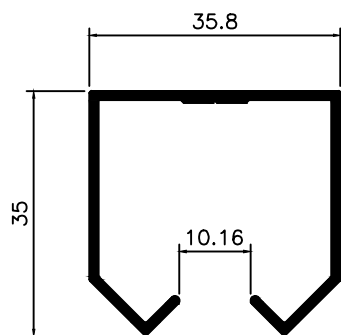

DS-473
0,440 Kg/m

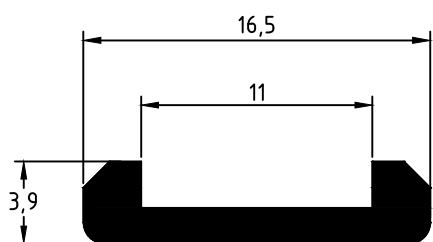

MAX-002
0,120 Kg/m

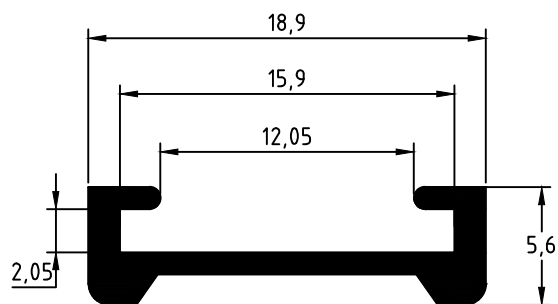

MAX-003
0,130 Kg/m